

DEHA

DEHA for boiler water treatment

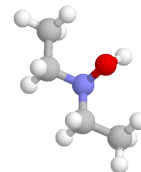

Recommended for low and medium pressure boilers

« All-in-One » product for 3 major effects :

- X Oxygen scavenger**
- X Magnetite barrier formation**
- X Condensate line protection** (V/L ratio = 1.26)

Strengths :

- ⇒ Good thermal stability
- ⇒ Good volatility and alkalinity
- ⇒ Passivator
- ⇒ Can be catalysed
- ⇒ Low toxicity

Consequences :

- ⇒ Better protection (especially in steam networks)
- ⇒ Operating reliability
- ⇒ Lower maintenance costs
- ⇒ Energy savings

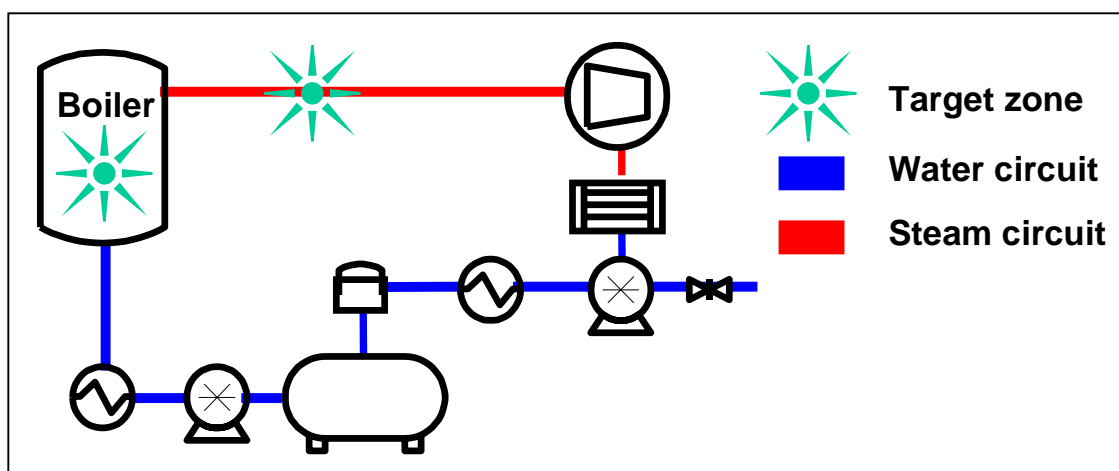

Neutralising amines for steam condensate control :

	V/L ratio *	Basicity (Kb x 10 ⁶)	ppm CO ₂ neutralised by 1 ppm amine
DEAE : Diethylaminoethanol	1.7	66	0.376
DMA2P : Dimethylamino-2-propanol	4.6	19	0.427

* at P = 1 bar, T = 100°C, pH = 10